

TEF-C

Self centering
Floating jaws

High precision pull-down 2+2+2 equalising

Ø 260 - 850 mm

- active pull-down
- tongue & groove
- 6 jaws 2+2+2



proofline® series
fully sealed-low maintenance

Application/customer benefits

- Clamping of thin walled workpieces
- Suitable for OP 10 or unique clamping applications
- Low radial deformation with 2+2+2 clamping
- Constant grip force and long lifetime ensure **constant quality of work pieces**
- Low profile, ideal for machines with limited Z axis stroke

Technical features

- 6-jaw-design
- active pull-down
- floating base jaws for 12 point contact
- centrifugal force compensation
- tongue & groove base jaws

- central bore for coolant and/or air
- permanent grease lubrication
- **proofline® chucks** = fully sealed – low maintenance

Standard equipment

6-jaw-chuck
Mounting bolts and grease gun

Ordering example

6-jaw-chuck TEF-C 260/A8

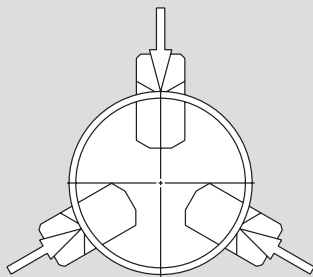

0 ≈ x

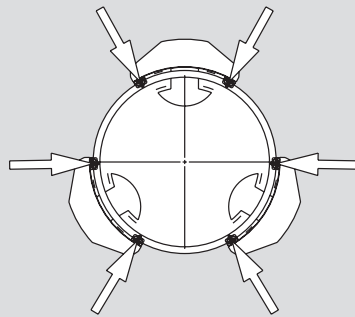

0 ≈ x/4

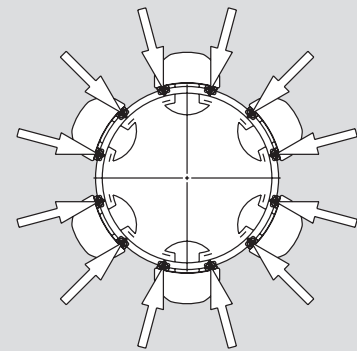

0 ≈ x/16

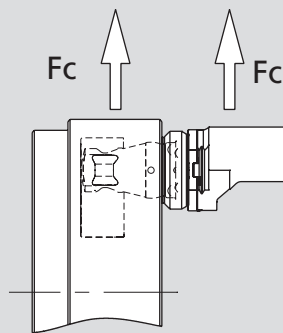

Very high centrifugal force compensation for very high speed

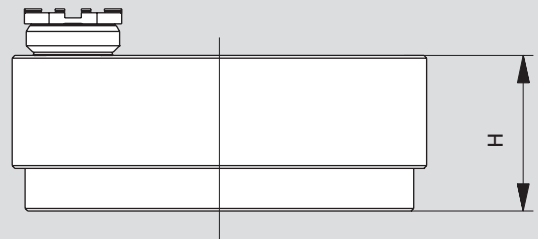

Very low profile and little limitation of the Z axis ideal for high production machines like the inverted spindle and frontal spindle lathes

Technical data

SMW-AUTOBLOK Type		TEF-C 260	TEF-C 320	TEF-C 400	TEF-C 530	TEF-C 650	TEF-C 850
Angular jaw stroke	deg.	5.2°	4.9°	4.9°	4.7°	4.7°	5°
Radial jaw stroke at distance h	mm	5.4	6	7	7.6	7.5	9.8
Angular compensation jaw stroke max.	deg.	±2.4°	±2.2°	±2.2°	±2.1°	±1.5°	±2.25°
Radial compensation at distance h max.	mm	±2.5	±2.7	±3.2	±3.5	±2	±4.5
Pull down movement (standard)	mm	0.1	0.1	0.1	0.2	0.8	0.4
Axial piston stroke	mm	24	29	29	35	35	37
Max. draw pull	kN	18	25	40	50	60	100
Max. gripping force at distance h	kN	44	60	96	120	120	180
Max. speed*	r.p.m.	4200	3500	2500	1800	1200	1200
Weight (plain back without top jaws)	kg	39	68	118	234	370	770
Moment of inertia (m·r ²)	kg·m ²	0.33	0.85	2.5	8.4	20	71
Recommended actuating cylinders		SIN-S 100	SIN-S 100	SIN-S 125	SIN-S 125	SIN-S 150	SIN-S 200

* The above maximum speed is allowed with standard weight/height top jaws and applying the full draw pull only. For more informations please contact SMW-AUTOBLOK.

High precision pull-down 2+2+2 equalising

Ø 260 - 850 mm

- active pull-down
- tongue & groove
- 6 jaws 2+2+2

TEF-C

Self centering
Floating jaws

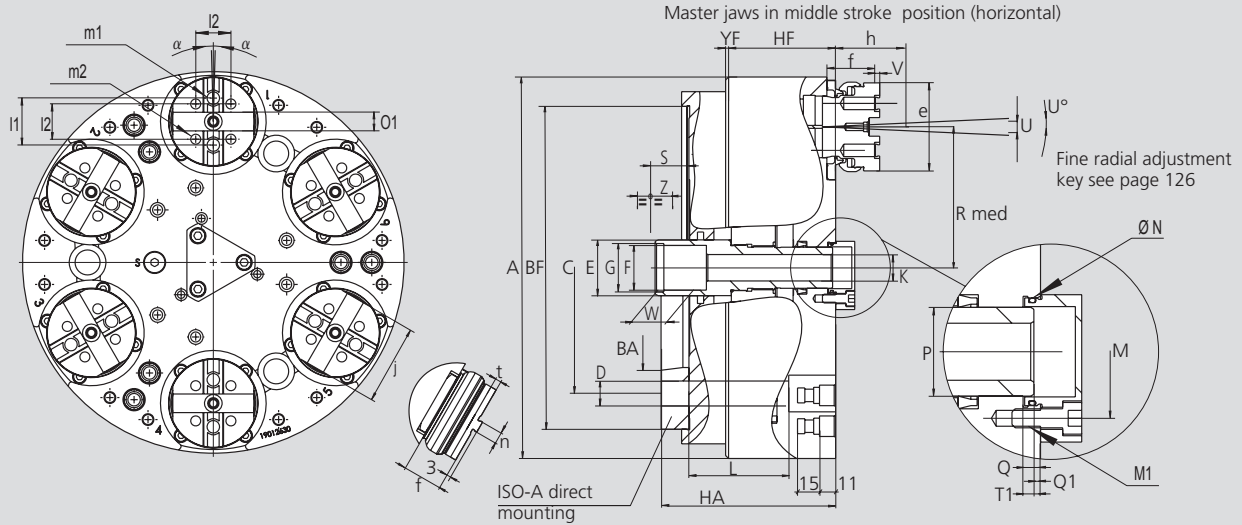

Subject to technical changes
For more detailed information please ask for customer drawing

SMW-AUTOBLOK Type			TEF-C 260		TEF-C 320		TEF-C 400		TEF-C 530		TEF-C 650		TEF-C 850	
Mounting			Z220	A8	Z280	A11	Z300	A11	Z380	A15	Z380	A15	Z520	A20
	A	mm	260		320		404		530		650		850	
	Bf/BA H6	mm	220	139.719	280	196.869	300	196.869	380	285.775	380	285.775	520	412.775
	C	mm	171.4		235		235		330.2		330.2		463.6	
	D	mm	17		21		21		26		26		27	
	E	mm	38		48		48		75		75		100	
	F	mm	M32 x 1.5		M38 x 1.5		M38 x 1.5		M60 x 1.5		M60 x 1.5		M80 x 2	
	G H8	mm	33		39		39		61		61		81	
	Hf/HA	mm	100	119	115	136	122	143	142	165	157	180	180	205
Through-hole	K	mm	18		25		25		52		52		75	
	L	mm	68		84		94		107		107		145	
	M	mm	42		63		63		75		75		*	
Thread/depth	M1	mm	M6/11		M6/11		M6/11		M8/16		M8/16		M8/16	
	N H8	mm	34		44		44		75		75		150	
	P	mm	28		36		36		65		65		100	
	Q	mm	5.5		7.5		7.5		9		9		18.5	
At middle stroke	Q1	mm	5		5.5		5.5		6.5		10.5		5	
At middle stroke	Rmed	mm	96		113		152		200		260		345	
At middle stroke	S	mm	23.1		23.5		18.3		36.3		25.5		22.6	
	T1	mm	13		13		13		15		12		*	
Radial stroke	U°	deg.	5.2°		4.9°		4.9°		4.7°		4.7°		5°	
Radial stroke (1)	U	mm	5.4		6		7		7.6		7.5		9.8	
Pull-down std.	V	mm	0.1		0.1		0.1		0.2		0.8		0.4	
	W	mm	25		30		30		26		26		30	
Axial piston stroke	Z	mm	24		29		29		35		35		37	
	α	deg.	±2°		±1.5°		±1.5°		±1.5°		±1°		±1.3°	
	e	mm	60		75		80		105		105		127	
	f	mm	27		33		33		32		32		46	
Reference height	h	mm	50		60		70		80		80		100	
	j	mm	55.2		65.2		72.2		100.2		100.2		116.2	
	l1	mm	32		38		44.4		63.5		63.5		63.5	
	l2	mm	24		32		36		48		48		54	
Thread/depth	m1	mm	M10/16		M12/18		M12/18		M16/20		M16/20		M20/25	
Thread/depth	m2	mm	M8/14		M10/14		M10/14		M12/17		M12/17		M16/24	
	n h8	mm	7.94		7.94		12.7		12.7		12.7		12.7	
	o1 H7	mm	12.68		12.68		19.03		19.03		19.03		19.03	
	t	mm	4		4		4		7		4		7	
	Yf	mm	5		5		6		6		6		6	

* Please ask for chuck drawing